

DEPARTMENT OF MECHANICAL ENGINEERING

QUESTION BANK YEAR/SEM :II/III

ENGINEERING MATERIALS AND METALLURGY

Unit-I- ALLOYS AND PHASE DIAGRAMS

PART-A

1. Define Peritectic and Eutectoid reactions.

The peritectic reaction also involves three solid in equilibrium, the transition is from a solid + liquid phase to a different solid phase when cooling. The inverse reaction occurs when heating.



The eutectoid one solid phase to two new solid phases. It also shows as V on top of a horizontal line in the phase diagram.



2. State the conditions under which two metallic elements will exhibit unlimited solid solubility.

A homogeneous crystalline phase contains two or more chemical species. Both substitutional and interstitial solid solutions are possible.

3. Define the terms "ferrite" and "austenite" in iron-carbon alloy system.

- α -Ferrite (BCC) Fe-C solution
- γ -Austenite (FCC) Fe-C solution

4. Define solute and solvent.

The component of a solution present in the greatest amount. It is the component that dissolves a solute. One component or element of a solution present in a minor concentration. It is dissolved in the solvent.

5. What are the different types of solid solutions?

- Substitution solid solutions
- Interstitial solid solutions

6. What is phase diagram? Also its importance.

A graphical representation of the relationships between environmental constraints (e.g., temperature and sometimes pressure), composition, and regions of phase stability, ordinarily under conditions of equilibrium.

7. Define cementite, pearlite.

Iron carbide (Fe₃C). A two-phase microstructure found in some steels and cast irons; it results from the transformation of austenite of eutectoid composition and consists of alternating layers (or lamellae) of ferrite and cementite.

8. What is meant by hypo eutectoid, hypereutectoid steel?

Hypoeutectoid alloy: For an alloy system displaying a eutectoid, an alloy for which the concentration of solute is less than the eutectoid composition.

Hypereutectoid alloy: For an alloy system displaying a eutectoid, an alloy for which the concentration of solute is greater than the eutectoid composition.

9. What are cooling curves?

Iron-carbon alloy of eutectoid composition. A plot containing such modified beginning and ending reaction curves is termed a continuous cooling transformation (CCT) diagram.

10. Define an Alloy?

A substance which is composed of two or more chemical elements such that metallic atoms predominate in composition and metallic bond and predominates is called an alloy.

11. What is the process in Recrystallization or process

The formation of a new set of strain-free grains within a previously cold-worked material; normally an annealing heat treatment is necessary.

12. What is the Spheroidizing?

Spheroidizing: For steels, a heat treatment carried out at a temperature just below the eutectoid in which the spheroidite microstructure is produced.

13. What is the purpose of normalizing?

Normalizing: For ferrous alloys, austenitizing above the upper critical temperature, then cooling in air. The objective of this heat treatment is to enhance toughness by refining the grain size.

14. State Gibbs phase rule.

In practical conditions for metallurgical and material systems, pressure can be treated as a constant (1 atm.).

Thus Condensed Gibbs phase rule is written as:

$$P + F = C + 2 \quad P + F = C + 1$$

15. Define the term solid solutions

A homogeneous crystalline phase contains two or more chemical species. Both substitution and interstitial solid solutions are possible.

16. How will you classify steels?

Based on carbon percentage in steel classified below

- Commercial pure irons % C < 0.008
- Low-carbon/mild steels 0.008 - %C - 0.3
- Medium carbon steels 0.3 - %C - 0.8
- High-carbon steels 0.8 - %C - 2.11
- Cast irons 2.11 < %C

17. State isomorphous system

Two component systems are classified based on extent of mutual solid solubility. Completely soluble in both liquid and solid phases.

E.g.: Cu-Ni, Ag-Au, Ge-Si, Al₂O₃-Cr₂O₃.

18. What is an equilibrium diagram?

Equilibrium phase diagrams represent the relationships between temperature, compositions and the quantities of phases at equilibrium.

19. What is Tie line rule?

At a point in a phase diagram, phases present and their composition along with relative fraction of phases can be computed.

PART-B

1. Neatly sketch labeled iron-carbon equilibrium diagram. Also explain the reaction involved.

Hints:

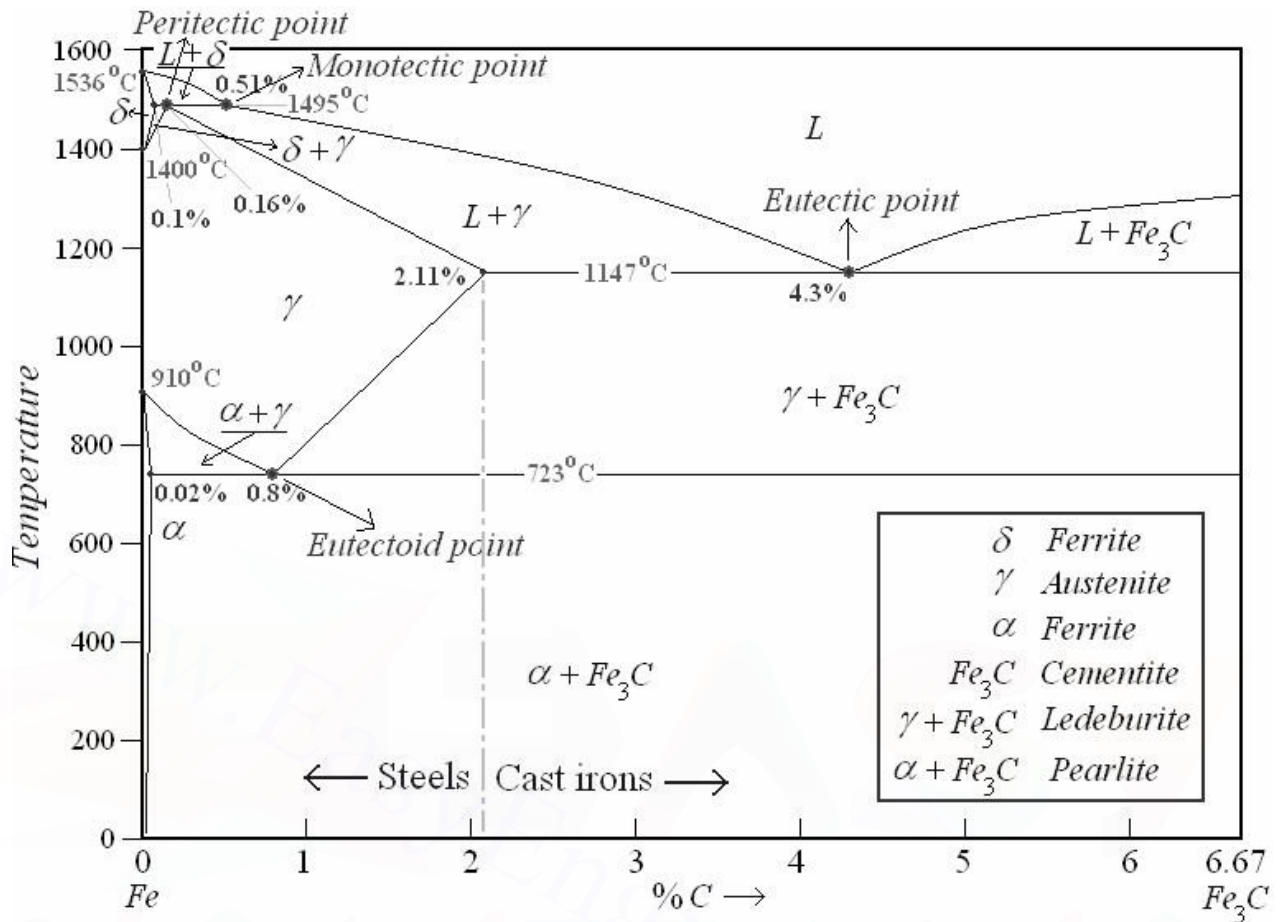

Reaction	Symbolic equation	Schematic presentation	Example
Eutectic	$L \rightarrow \alpha + \beta$		Fe-C, 4.27% C, 1147°C
Eutectoid	$\alpha \rightarrow \beta + \gamma$		Fe-C, 0.80% C, 723°C
Peritectic	$L + \alpha \rightarrow \beta$		Fe-C, 0.16% C, 1495°C
Peritectoid	$\alpha + \beta \rightarrow \gamma$		
Monotectic	$L_1 \rightarrow L_2 + \alpha$		Fe-C, 0.51% C, 1495°C

2. Discuss the similarities and difference between substitutional and interstitial solid solutions.

Hints:

Substitutional

- These two elements are completely soluble in one another at all proportions.
- aforementioned rules that govern degree of solubility, the atomic radii for copper and nickel are 0.128 and 0.125 nm, respectively,
- both have the **FCC** crystal structure, and their electronegativities are 1.9 and 1.8

Interstitial

- Impurity atoms fill the voids or interstices among the host atoms.
- For metallic materials that have relatively **high atomic packing** factors, these interstitial positions are relatively small.
- Consequently, the atomic diameter of an interstitial impurity must be substantially smaller than that of the host atoms.

3. Explain the Binary phase diagram?

Hints:

Isomorphous Binary System

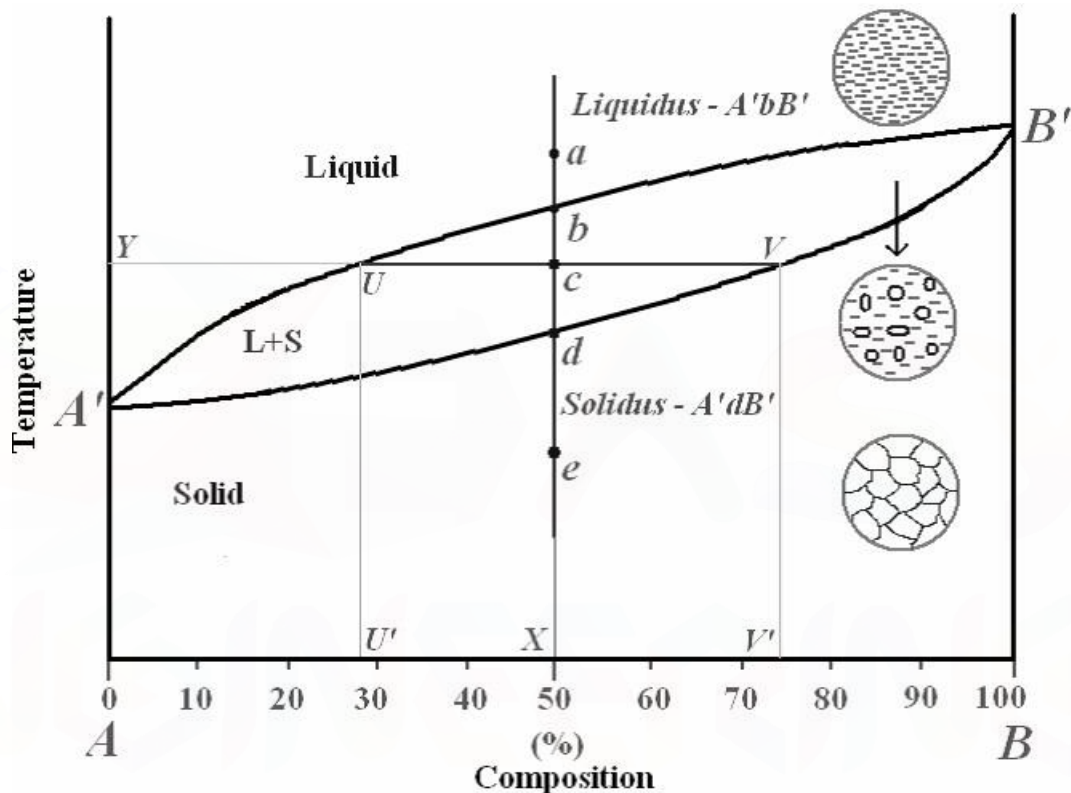

- If a system consists of two components, equilibrium of phases exist is depicted by binary phase diagram.
- For most systems, pressure is constant, thus independently variable parameters are – temperature and composition.
- The liquid L is a homogeneous liquid solution composed of both copper and nickel.
- The α phase is a substitutional solid solution consisting of both Cu and Ni atoms, and having an FCC crystal structure.
- Complete liquid and solid solubility of the two components.

4. How can construct the phase diagram binary eutectic alloy system?

Hints:

Eutectic Binary System

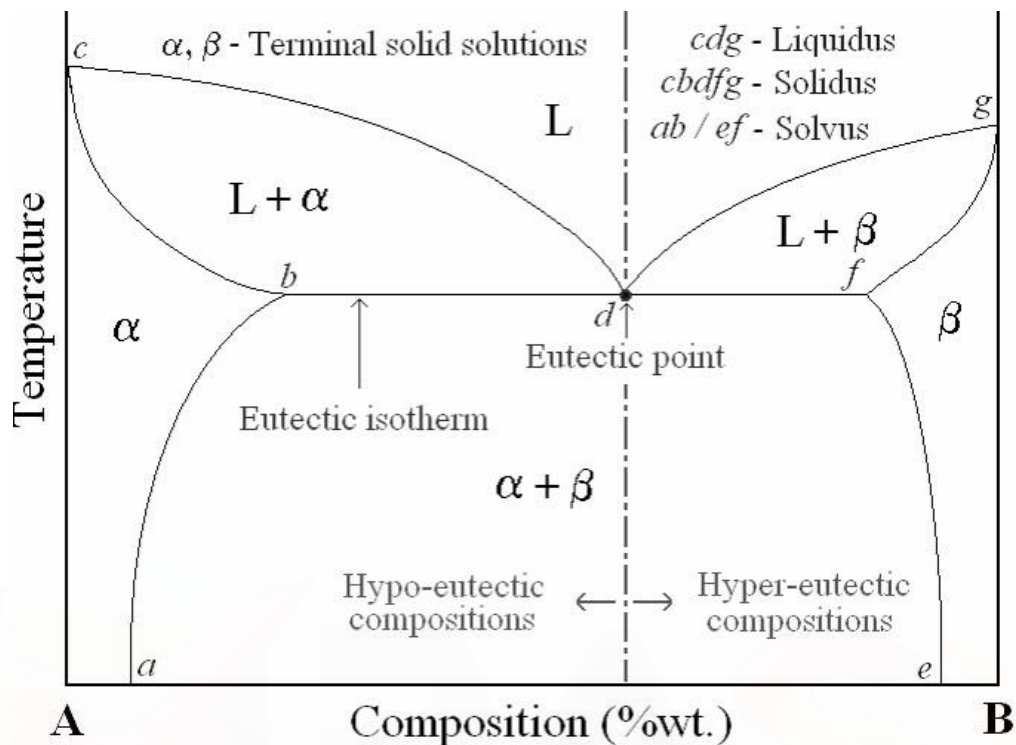

- A number of features of this phase diagram are important and worth noting.
- First of all, three single-phase regions are found on the diagram: α , β and liquid.
- The α phase is a solid solution rich in copper; it has silver as the solute component and an FCC crystal structure.
- The β phase solid solution also as an FCC structure, but copper is the solute.

5. Draw the iron carbide equilibrium diagram?

Hints:

- At room temperature the stable form, called ferrite, or α iron, has a BCC crystal structure.
- Ferrite experiences a polymorphic transformation to FCC austenite, or γ iron, at 912 °C (1674 °F).
- This austenite persists to 1394°C (2541°F), at which temperature the FCC austenite reverts back to a BCC phase known as δ ferrite,

6. Explain the primary crystallization of hypereutectoid steels?

Hints:

- Steels having less than 0.8% carbon are called hypo-eutectoid steels (hypo means "less than").
- Consider the cooling of a typical hypo-eutectoid alloy along line $y-y'$.
- At high temperatures the material is entirely austenite.
- Upon cooling it enters a region where the stable phases are ferrite and austenite.
- The low-carbon ferrite nucleates and grows, leaving the remaining austenite richer in carbon

7. Explain the classification of steel also explain properties and application.

Hints:

Based on carbon percentage in steel classified below

➤ <u>Low-carbon/mild steels</u> <u>0.008 - %C - 0.3</u>	➤ <u>Medium carbon steels 0.3 -</u> <u>%C - 0.8</u>	➤ <u>High-carbon steels 0.8-</u> <u>%C - 2.11</u>
<ul style="list-style-type: none"> ✓ Properties: <ul style="list-style-type: none"> ❖ Tough, ductile and malleable ❖ Easily joined and welded ❖ Poor resistance to corrosion ✓ Application: <ul style="list-style-type: none"> ❖ Nails, screws, car bodies ❖ Structural Steel used in the construction industry 	<ul style="list-style-type: none"> ✓ Properties: <ul style="list-style-type: none"> ❖ More strength and hardness BUT ❖ Less ductile and malleable ✓ Application: <ul style="list-style-type: none"> ❖ Structural steel ❖ Rails ❖ Garden tools 	<ul style="list-style-type: none"> ✓ Properties: <ul style="list-style-type: none"> ❖ Very hard but offers Higher Strength ❖ Less ductile ❖ Less malleable ✓ Application: <ul style="list-style-type: none"> ❖ Structural steel ❖ Rails ❖ Garden tools

8. Explain the following reactions with reference phase diagram

Hints:

Reaction	Symbolic equation	Schematic presentation	Example
Eutectic	$L \rightarrow \alpha + \beta$		Fe-C, 4.27% C, 1147°C
Eutectoid	$\alpha \rightarrow \beta + \gamma$		Fe-C, 0.80% C, 723°C
Peritectic	$L + \alpha \rightarrow \beta$		Fe-C, 0.16% C, 1495°C
Peritectoid	$\alpha + \beta \rightarrow \gamma$		
Monotectic	$L_1 \rightarrow L_2 + \alpha$		Fe-C, 0.51% C, 1495°C

UNIT-II - HEAT TREATMENT

PART- A

1. What is "critical cooling rate" in hardening of steels?

This critical cooling rate, when included on the continuous transformation diagram, will just miss the nose at which the pearlite transformation begins

2. What is meant by "heat treatment"? Also its purpose.

Heat treatment of a metal or alloy is a technological procedure, including controlled heating and cooling operations, conducted for the purpose of changing the alloy microstructure and resulting in achieving required properties.

3. What is meant by normalizing? Also its purpose.

An annealing heat treatment called normalizing is used to refine the grains (i.e., to decrease the average grain size) and produce a more uniform and desirable size distribution; fine-grained pearlitic steels are tougher than coarse-grained ones.

4. What is quenching? List some of the quenching medium.

Conventional heat treatment procedures for producing martensitic steels ordinarily involve continuous and rapid cooling of an austenitized specimen in some type of quenching medium, such as water, oil, or air.

5. What is the process in Full Annealing?

Annealing is a heat treatment procedure involving heating the alloy and holding it at a certain temperature (annealing temperature), followed by controlled cooling.

6. What is the Spheroidizing?

Spheroidizing. For steels, a heat treatment carried out at a temperature just below the eutectoid in which the spheroidite microstructure is produced.

7. What is Normalising?

Normalizing. For ferrous alloys, austenitizing above the upper critical temperature, then cooling in air. The objective of this heat treatment is to enhance toughness by refining the grain size.

8. What is the abbreviation of TTT-diagram?

T-T-T diagram is also called isothermal transformation diagram. It is a plot of temperature versus the logarithm of time for a steel alloy of definite composition. It is used to determine when transformation begin and end for an isothermal (constant temperature) heat treatment of a previously austenitized alloy.

9. What is meant by aging?

A heat treatment used to precipitate a new phase from a supersaturated solid solution. For precipitation hardening, it is termed artificial aging.

10. Define the term age hardening.

The term as applied to soft or low carbon steels, relates to slow, gradual changes that take place in properties of steels after the final treatment. These changes, which bring about a condition of increased hardness, elastic limit, and tensile strength with a consequent loss in ductility, occur during the period in which the steel is at normal temperatures.

11. Briefly notes on Martempering.

The process of quenching an austenitized ferrous alloy is a medium at a temperature in the upper part of the martensite range, or slightly above that range, and holding it in the medium until the temperature throughout the alloy is substantially uniform is known as martempering. The alloy is then allowed to cool in air through the martensite range.

12. What is age hardening or precipitation hardening?

By uniformly dispersing extremely small particles within the original phase matrix the strength and hardness of metal alloys may be enhanced; this process of heat treatment is called precipitation hardening or age hardening.

13. What is meant by heat treatment? What are the different methods of heat treatment?

Heating and cooling a solid metal or alloy in such a way as to obtain desired conditions or properties is called heat treatment. There are different methods of strengthening and hardening by heat treatment.

They are

- ❖ Age hardening (precipitation hardening)
- ❖ Annealing
- ❖ Normalizing
- ❖ Tempering and
- ❖ Case hardening

14. What are cast irons and what are their basic types?

Any ferrous alloy made up primarily of iron with about 2% or more carbon is considered to be cast iron. Most commercial alloys contain from about 2.5% to 3.8% carbon. There are four basic types of cast iron

- ❖ Grey cast iron
- ❖ White cast iron
- ❖ Malleable iron

15. Differentiate annealing and normalizing treatment.

Annealing	Normalizing
<p>a) A generic term used to denote a heat treatment wherein the microstructure and, consequently, the properties of a material are altered.</p> <p>b) ‘‘Annealing’’ frequently refers to a heat treatment whereby a previously cold-worked metal is softened by allowing it to recrystallize.</p>	<p>a) For ferrous alloys, austenitizing above the upper critical temperature, then cooling in air.</p> <p>b) The objective of this heat treatment is to enhance toughness by refining the grain size.</p>

16. What do you mean by hardenability?

A measure of the depth to which a specific ferrous alloy may be hardened by the formation of martensite upon quenching from a temperature above the upper critical temperature.

PART-B

1. What is heat treatment? And explain the various stages of heat treatment process.

Hints:

- Heat treatment of a metal or alloy is a technological procedure, including controlled heating and cooling operations, conducted for the purpose of changing the alloy microstructure and resulting in achieving required properties.
- There are two general objectives of heat treatment: hardening and annealing.
- **Hardening** is a process of increasing the metal hardness, strength, toughness, fatigue resistance.
- **Annealing** is a heat treatment procedure involving heating the alloy and holding it at A certain temperature (annealing temperature), followed by controlled cooling.

2. Describe Normalizing process of heat treatment.

Hints:

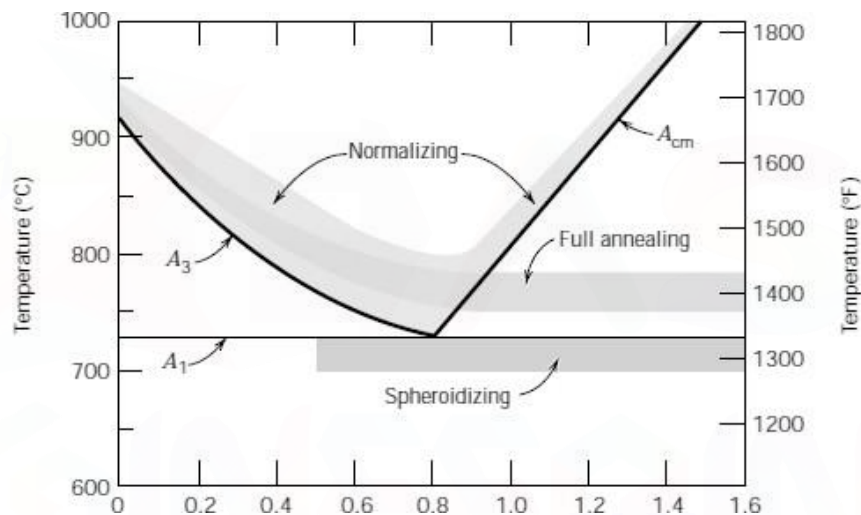

- Steels that have been plastically deformed by, for example, a rolling operation, consist of grains of pearlite (and most likely a proeutectoid phase)
- Normalizing is accomplished by heating at approximately 55 to 85°C (100 to 150°F) above the upper critical temperature, which is, of course, dependent on composition.

3. Explain the process of martempering .Compare and contrast it with austempering.

Hints:

- Martempering is used to minimize distortion and cracking.
- It involves cooling the austenized steel to temperature just above M_s Temperature, holding it there until temperature is uniform.
- Cooling at a moderate rate to room temperature before austenite-to-bainite transformation begins.
- The final structure of martempered steel is tempered Martensite.
- Austempering involves austenite-to-bainite transformation.
- Thus, the final structure of austempered steel is bainite.

4. Differentiate between hardness and hardenability.

Hints:

- The influence of alloy composition on the ability of a steel alloy to transform to martensite for a particular quenching treatment is related to a parameter called hardenability.
- Hardenability is not “hardness,” which is the resistance to indentation; rather, hardenability is a qualitative measure of the rate at which hardness drops off with distance into the interior of a specimen as a result of diminished martensite content

5. Discuss the uses of hardenability curves.

Hints:

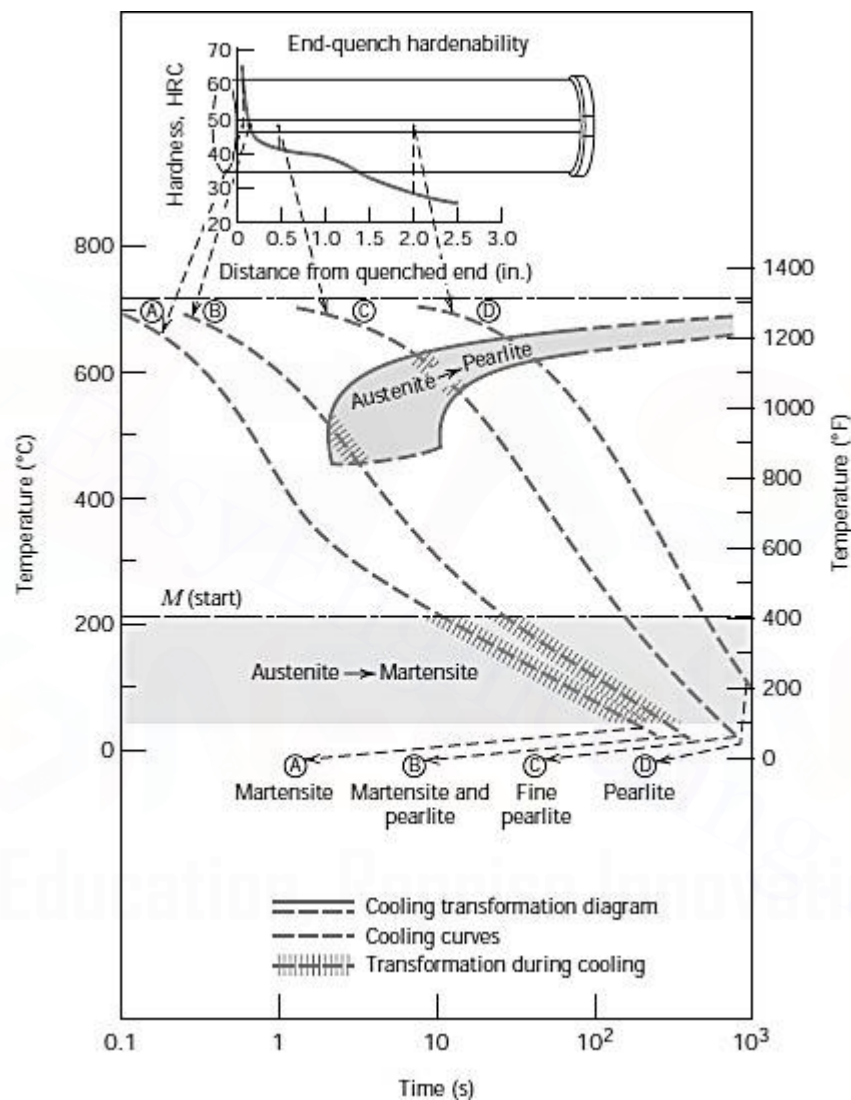

- The quenched end is cooled most rapidly and exhibits the maximum hardness; 100% martensite is the product at this position for most steels.
- Cooling rate decreases with distance from the quenched end, and the hardness also decreases.
- With diminishing cooling rate more time is allowed for carbon diffusion and the formation of a greater proportion of the softer pearlite
- It is mixed with martensite and bainite.

6. Explain various tempering process.

Hints:

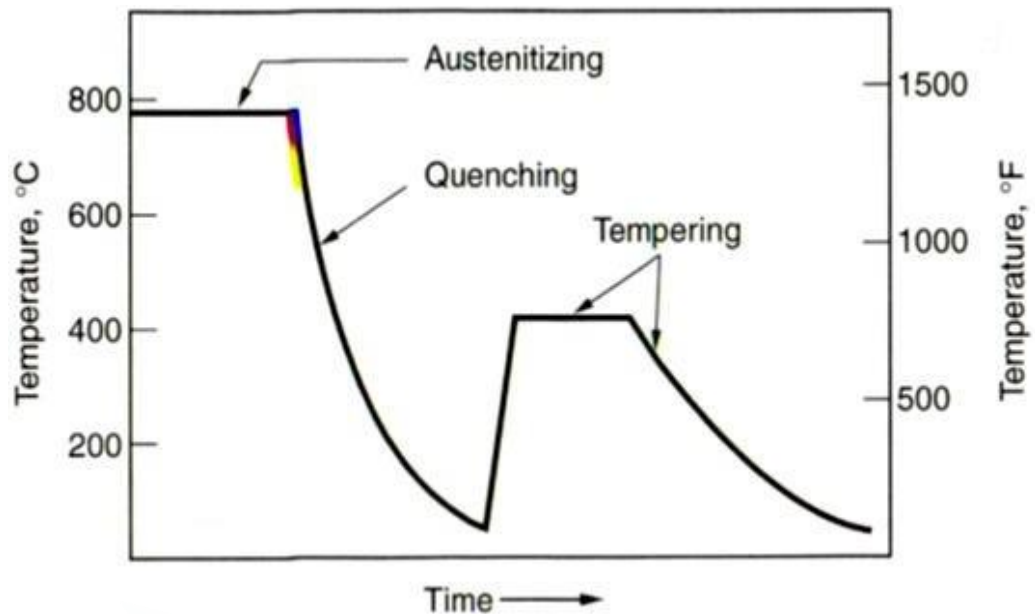

Martensite (BCT, single phase) \longrightarrow Tempered Martensite (+ α Fe₃C phases)

- The microstructural product resulting from a tempering heat treatment of martensitic steel.
- The microstructure consists of extremely small and uniformly dispersed cementite particles embedded within a continuous ferrite matrix.
- Toughness and ductility are enhanced significantly by tempering.

7. What are TTT diagrams? How its drawn?

Hints:

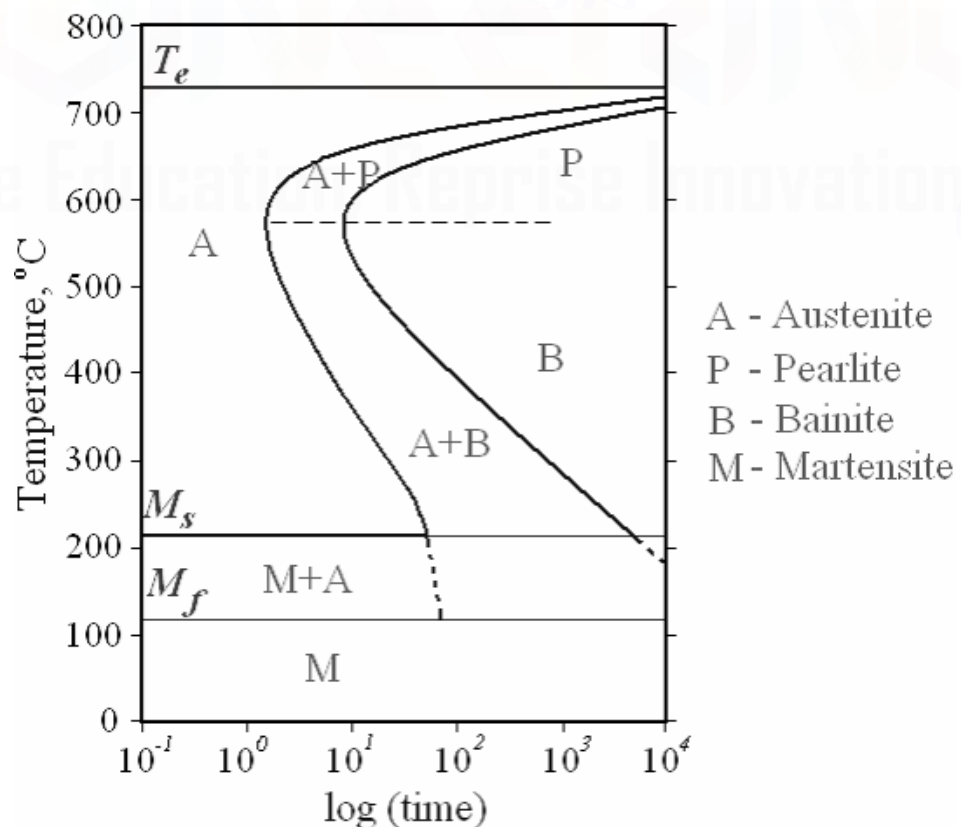

- Heat Treatment is the controlled heating and cooling of metals to alter their physical and mechanical properties without changing the product shape.
- T-T-T diagram is also called isothermal transformation diagram.
- It is a plot of temperature versus the logarithm of time for a steel alloy of definite composition.
- It is used to determine when transformation begins and ends for an isothermal (constant temperature) heat treatment of a previously austenitized alloy.

8. What is a CCT diagram? And write short notes on critical cooling rate.

- For the continuous cooling of a steel alloy, there exists a critical quenching rate, which represents the minimum rate of quenching that will produce a totally martensitic structure.
- This critical cooling rate, when included on the continuous transformation diagram, will just miss the nose at which the pearlite transformation
- Each is experimentally determined for an alloy of specified composition, the variables being temperature and time.

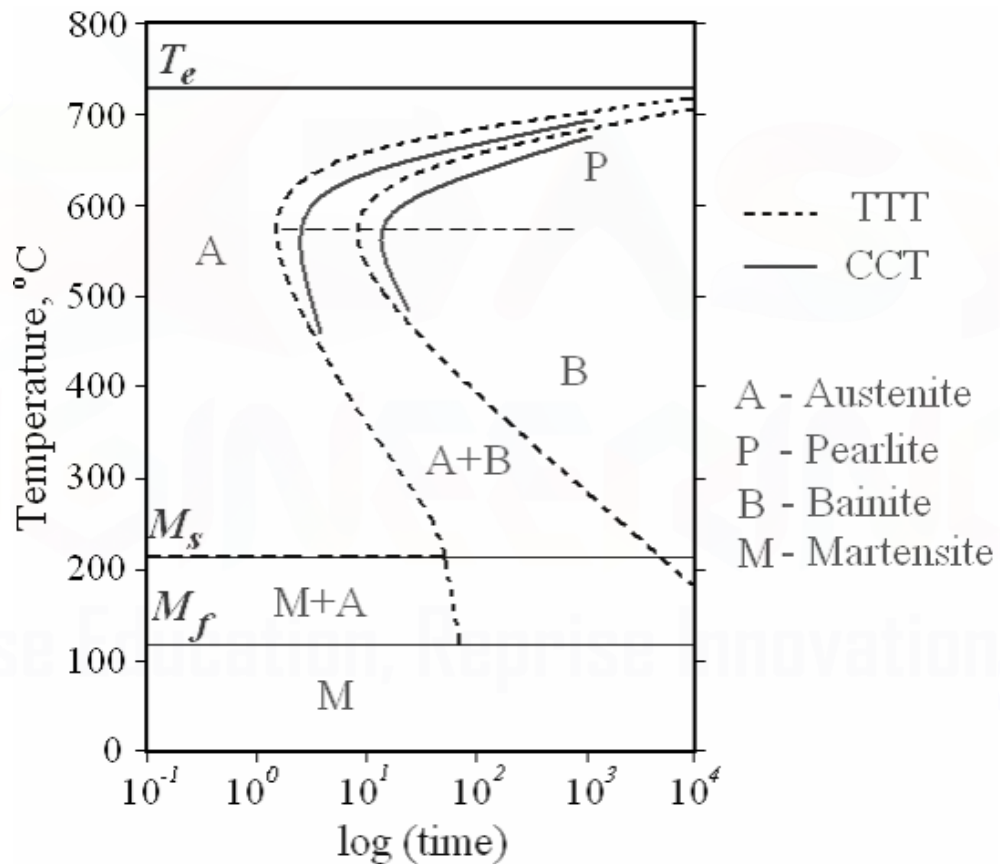

UNIT-III - FERROUS AND NON-FERROUS METALS

PART-A

1. Name the industrially important copper alloys.

- a) Copper-Zinc (the Brasses)
- b) Copper-Tin (the Tin Bronzes)
- c) Copper-Tin-Phosphorus (the Phosper Bronzes)
- d) Copper-Aluminium (the Aluminium Bronzes)
- e) Copper-Nickel (the Cupro-Nickels)

2. What is HSLA ? explain with respect to composition properties and application.

Low-carbon alloys are the **high-strength, low-alloy (HSLA)steels**. They contain other alloying elements such as copper, vanadium, nickel, andmolybdenum in combined concentrations as high as 10 wt%

Properties

- Possess higherstrengths than the plain low-carbon steels.
- Most may be strengthened by heat treatment, giving tensile strengths in excess of 480 MPa.
- They are ductile, formable, and machine able.
- The HSLA steels are more resistant to corrosion than the plain carbon steels.

Application

Bridges, Towers, Support Columns In High-Rise Buildings, And Pressure Vessels.

3. List the important properties of HSLA

Properties

- Possess higherstrengths than the plain low-carbon steels.
- Most may be strengthened by heat treatment, giving tensile strengths in excess of 480 MPa.
- They are ductile, formable, and machine able.
- The HSLA steels are more resistant to corrosion than the plain carbon steels.

4. What are bronze ? list the use of bronze.

Copper alloys containing tin, lead, aluminum, silicon andnickel are classified as bronzes. Cu-Sn Bronze is one of the earliest alloys to be discovered asCu ores invariably contain Sn. Stronger than brasses with good corrosion and tensileproperties; can be cast, hot worked and cold worked.Wide range of applications: ancient Chinese cast artifacts,skateboard ball bearings, surgical and dental instruments.

5. What is air hardening steel?

Alloy steel which may be hardened by cooling in air from a temperature above the transformation range. Such steels attain their martensitic structure without going through the quenching process. Additions of chromium, nickel, molybdenum and manganese are effective toward this end.

6. What is AISI STEELS?

Steels of the American Iron and Steel Institute. Common and alloy steels have been numbered in a system essentially the same as the SAE. The AISI system is more elaborate than the SAE in that all numbers are preceded by letters: "A" represents basic open-hearth alloy steel, "B" acid Bessemer carbon steel, "C" basic open-hearth carbon steel, "CB" either acid Bessemer or basic open-hearth carbon steel, "E" electric furnace

7. What is an alloy?

A substance which is composed of two or more chemical elements such that metallic atoms predominate in composition and metallic bond and predominates is called an alloy.

8. What is alloy steel?

Steel containing substantial quantities of elements other than carbon and the commonly-accepted limited amounts of manganese, sulfur, silicon, and phosphorous. Addition of such alloying elements is usually for the purpose of increased hardness, strength or chemical resistance. The metals most commonly used for forming alloy steels are: nickel, chromium, silicon, manganese, tungsten, molybdenum and vanadium. "Low Alloy" steels are usually considered to be those containing a total of less than 5% of such added constituents.

9. What is alpha brass?

A copper-zinc alloy containing up to 38% of zinc. Used mainly for cold working.

10. What is austenitic steel?

Steel, because of the presence of alloying elements, such as manganese, nickel, chromium, etc., shows stability of Austenite at normal temperatures.

11. How bainite is formed?

A slender, needle-like (acicular) microstructure appearing in spring steel strip characterized by toughness and greater ductility than tempered Martensite. Bainite is a decomposition product of Austenite best developed at interrupted holding temperatures below those forming fine pearlite and above those giving Martensite.

12. What is ferritic stainless steel?

Has a body centered cubic (BCC) structure. These alloys are the chromium stainless steels containing low carbon levels. They are hardenable primarily by cold working, although some will harden slightly by heat treating. Ferritic stainless steels work harden much slower than austenitic stainless steels

13. Define the structure of Pearlite.

Lamellar structure resembling mother of pearl. A compound of iron and carbon occurring in steel as a result of the transformation of austenite into aggregations of ferrite and iron carbide.

14. What is phosphor bronze? State its applications.

Copper base alloys, with 3.5 to 10% of tin, to which has been added in the molten state phosphorous in varying amounts of less than 1% for deoxidizing and strengthening purposes. Because of excellent toughness, strength, fine grain, resistance to fatigue and wear, and chemical resistance, these alloys find general use as springs and in making fittings. It has corrosion resisting properties comparable to copper.

15. What is pig iron?

Iron produced by reduction of iron ore in a blast furnace. Pig iron contains approximately 92% iron and about 3.5% carbon. The balance is largely silicone and manganese with a small percentage of phosphorus, sulphur, and other impurities.

PART-B

1. Give the classification of steels , and give the properties and application of high carbon and low carbon steels.

Hints:

- The high-carbon steels, normally having carbon contents between 0.60 and 1.4 wt%, are the hardest, strongest, and yet least ductile of the carbon steels.
- The tool and die steels are highcarbon alloys, usually containing chromium, vanadium, tungsten, and molybdenum.

<i>AISI/SAE or ASTM Number</i>	<i>Tensile Strength [MPa (ksi)]</i>	<i>Yield Strength [MPa (ksi)]</i>	<i>Ductility [%EL in 50 mm (2 in.)]</i>	<i>Typical Applications</i>
<i>Plain Low-Carbon Steels</i>				
1010	325 (47)	180 (26)	28	Automobile panels, nails, and wire
1020	380 (55)	205 (30)	25	Pipe; structural and sheet steel
A36	400 (58)	220 (32)	23	Structural (bridges and buildings)
A516 Grade 70	485 (70)	260 (38)	21	Low-temperature pres- sure vessels
<i>High-Strength, Low-Alloy Steels</i>				
A440	435 (63)	290 (42)	21	Structures that are bolted or riveted
A633 Grade E	520 (75)	380 (55)	23	Structures used at low ambient temperatures
A656 Grade 1	655 (95)	552 (80)	15	Truck frames and rail- way cars

2. What are alloy elements in steel? Explain them.

Hints:

- Manganese – strength and hardness; decreases ductility and weldability; effects hardenability of steel.
- Phosphorus – increases strength and hardness and decreases ductility and notch impact toughness of steel.
- Sulfur decreases ductility and notch impact toughness Weldability decreases. Found in the form of sulfide inclusions.
- Silicon – one of the principal deoxidizers used in steel making. In low-carbon steels, silicon is generally detrimental to surface quality.
- Copper – detrimental to hot-working steels; beneficial to corrosion resistance (Cu>0.20%)
- Nickel - ferrite strengthener; increases the hardenability and impact strength of steels.
- Molybdenum increases the hardenability; enhances the creep resistance of low-alloy steels

3. What is HSLA and explain the properties and application?

Hints:

HSLA (high strength low alloy) steels:

Relatively strong, low-carbon steels, with less than about 10 wt% total of alloying element.

- They can be strengthened by heat treatment.
- Ductile and formable.
- Alloying addition – Cu, V, W, Ni, Cr, Mo, etc.
- Typical applications: support columns, pressure vessels, bridge beams.

4. With part of phase diagram and relevant graphs explain precipitation hardening treatment of Al-Cu alloy.

Hints:

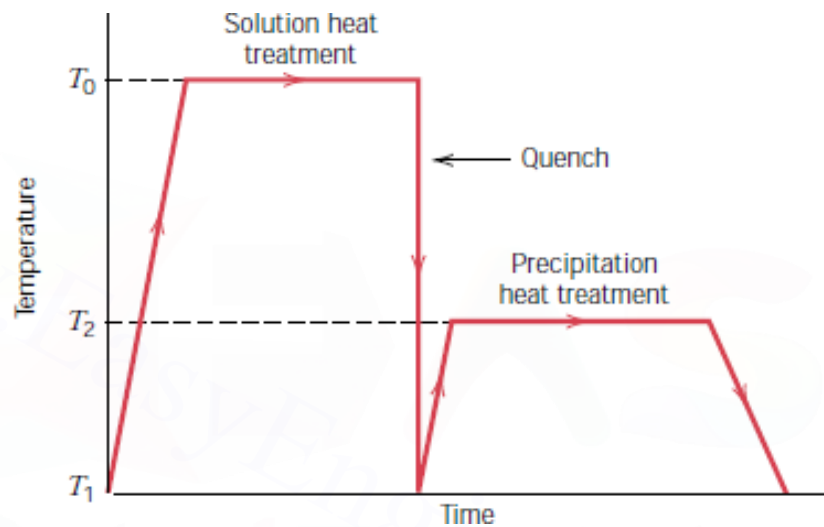

Age hardening in Al -Cu alloys

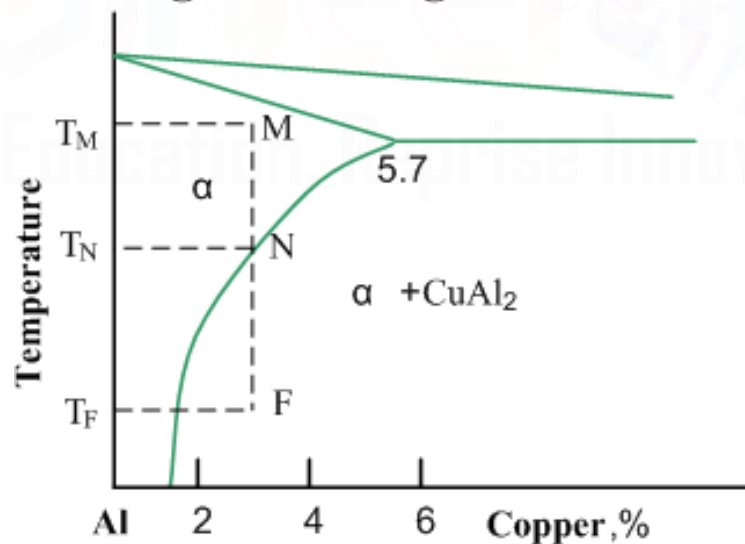

5. Discuss the composition, properties of any four copper alloys.

Hints:

Compositions, Properties and Application of some Cu Alloys

Name	UNS No.	Compos. (wt.%)	Condition	YS (MPa)	UTS (MPa)	%El	Applications
Electrolytic Copper	C11000	0.04 O	Annealed	69	220	45	Electrical wires, roofing, nails, rivets
Cartridge brass	C26000	30.0 Zn	Cold-rolled	435	525	8	Automotive radiator core, lamp fixture, ammunition.
Phosphor bronze	C51000	5.0 Sn, 0.25 P	Annealed	130	325	64	Bellows, clutch disk, diaphragm, fuse clips, springs
Yellow brass (Leaded)	C85400	29 Zn, 3.0 Pb, 1 Sn	As cast	83	234	35	Furniture, radiator fittings, battery clamps, light fixtures
Al bronze	C95400	11 Al, 4 Fe	As cast	241	586	18	Bearings, bushings, valve seats and guards
Beryllium copper	C17200	1.9 Be, 0.2 Co	Precipitation hardened	965	1140	10	Electrical, valves, pumps
Cu - Ni	C71500	30 Ni	Annealed	125	380	36	Condenser, heat-exchanger, piping, valves
Tin bronze	C90500	10 Sn, 2 Zn	As cast	152	310	25	Bearings, bushing, piston rings, gears

6. Explain the composition, properties of some aluminium alloys.

Hints:

- Aluminum and its alloys are characterized by a relatively low density (2.7 g/cm³ as compared to 7.9 g/cm³ for steel),
- high electrical and thermal conductivities, and a resistance to corrosion aluminum alloys are classified as either cast or wrought
- Aluminum has an FCC crystal structure; its ductility is retained even at very low temperatures.
- Nonheat-treatable alloys consist of a single phase, for which an increase in strength is achieved by solid solution strengthening.

7. Write short notes on types of cast iron.

Hints:

Though ferrous alloys with more than 2.14 wt.% C are designated as cast irons, commercially cast irons contain about 3.0-4.5% C along with some alloying additions.

Gray cast iron: These alloys consist of carbon in the form of graphite flakes, which are surrounded by either ferrite or pearlite.

White cast iron: When Si content is low (< 1%) in combination with faster cooling rates, there is no time left for cementite to get decomposed, thus most of the brittle cementite remains.

Nodular (or ductile) cast iron: Alloying additions are of prime importance in producing these materials. Small additions of Mg / Ce to the gray cast iron melt before casting can result in graphite to form nodules or sphere-like particles.

Malleable cast iron: These are formed after heat treating white cast iron. Heat treatments involve heating the material up to 800-900°C, and keep it for long hours, before cooling it to room temperature.

8. Write notes on types of steels?

<p>➤ <u>Low-carbon/mild steels</u> <u>0.008 - %C - 0.3</u></p> <p>✓ Properties:</p> <ul style="list-style-type: none">❖ Tough, ductile and malleable❖ Easily joined and welded❖ Poor resistance to corrosion <p>✓ Application:</p> <ul style="list-style-type: none">❖ Nails, screws, car bodies❖ Structural Steel used in the construction industry	<p>➤ <u>Medium carbon steels 0.3 - %C - 0.8</u></p> <p>✓ Properties:</p> <ul style="list-style-type: none">❖ More strength and hardness BUT❖ Less ductile and malleable <p>✓ Application:</p> <ul style="list-style-type: none">❖ Structural steel❖ Rails❖ Garden tools	<p>➤ <u>High-carbon steels 0.8- %C - 2.11</u></p> <p>✓ Properties:</p> <ul style="list-style-type: none">❖ Very hard but offers Higher Strength❖ Less ductile❖ Less malleable <p>✓ Application:</p> <ul style="list-style-type: none">❖ Structural steel❖ Rails❖ Garden tools
---	--	---

UNIT-IV - NON-METALLIC MATERIALS

PART-A

1. What is polymorphism?

The ability of a material to exist in more than one crystallographic structure. Numerous metals change in crystallographic structure at transformation temperatures during heating or cooling. If the change is reversible, it is allotropy. The allotropy of iron, particularly the changes between the alpha body-centered and the gamma face centered form, is of fundamental importance in the hardening of steel.

2. What are the Classification in Polymers

Polymers are classified in many ways. The prime classification based on their industrial usage is: plastics and elastomers.

3. What are the Classification in Plastics?

Based on their temperature dependence of their structure as

- Thermo
- Thermosetting

4. Define Elastomers

These polymers are known for their high elongations, which are reversible upon release of applied loads. They consist of coil-like molecular chains, which straighten up on application of load.

E.g.: natural and synthetic rubber.

5. What is Strengthening polymers

Polymers' resistance to deformation—strength – is influenced by many parameters. For thermoplastics: average molecular mass, degree of crystallization, presence of side groups, presence of polar and other specific atoms, presence of phenyl rings in main chains and addition of reinforcements.

6. Define Acrylonitrile-butadiene-styrene (ABS):

- **Characteristics:** Outstanding strength and toughness, resistance to heat distortion; good electrical properties; flammable and soluble in some organic solvents.
- **Application:** Refrigerator lining, lawn and garden equipment, toys, highway safety devices.

7. Define Acrylics (poly-methyl-methacrylate)

- **Characteristics:** Outstanding light transmission and resistance to weathering; only fair mechanical properties.
- **Application:** Lenses, transparent aircraft enclosures, drafting equipment, outdoor signs

8. Define Fluorocarbons (PTFE or TFE)

- **Characteristics:** Chemically inert in almost all environments, excellent electrical properties; low coefficient of friction; may be used to 260o C; relatively weak and poor cold-flow properties.
- **Application:** Anticorrosive seals, chemical pipes and valves, bearings, anti adhesive coatings, high temperature electronic parts.

9. Define Polyamides (nylons)

- **Characteristics:** Good mechanical strength, abrasion resistance, and toughness; low coefficient of friction; absorbs water and some other liquids.
- **Application:** Bearings, gears, cams, bushings, handles, and jacketing for wires and cables

10. Define Polycarbonates

- **Characteristics:** Dimensionally stable; low water absorption; transparent; very good impact resistance and ductility.
- **Application:** Safety helmets, lenses light globes, base for photographic film

11. Define Polyethylene

- **Characteristics:** Chemically resistant and electrically insulating; tough and relatively low coefficient of friction; low strength and poor resistance to weathering.
- **Application:** Flexible bottles, toys, tumblers, battery parts, ice trays, film wrapping materials.

12. Define Polypropylene

- **Characteristics:** Resistant to heat distortion; excellent electrical properties and fatigue strength; chemically inert; relatively inexpensive; poor resistance to UV light.
- **Application:** Sterilizable bottles, packaging film, TV cabinets, luggage

12. Define Polystyrene

- **Characteristics:** Excellent electrical properties and optical clarity; good thermal and dimensional stability; relatively inexpensive
- **Application:** Wall tile, battery cases, toys, indoor lighting panels, appliance housings.

13. Define Polyester (PET or PETE)

- **Characteristics:** One of the toughest of plastic films; excellent fatigue and tear strength, and resistance to humidity acids, greases, oils and solvents
- **Application:** Magnetic recording tapes, clothing, automotive tire cords, beverage containers.

14. Differentiate thermosetting and thermoplastic polymers.

Thermosetting	Thermoplastic
a) Covalent bonds with cross-linking between chains. b) They are more strength and harder than thermo plastic.	a) They are linear chain without cross-linking and branching. b) they are usually supplied as granular materials

15. Define Epoxies

- **Characteristics:** Excellent combination of mechanical properties and corrosion resistance; dimensionally stable; good adhesion; relatively inexpensive; good electrical properties.
- **Application:** Electrical moldings, sinks, adhesives, protective coatings, used with fiberglass laminates.

16. Define Phenolics

- **Characteristics:** Excellent thermal stability to over 150°C; may be compounded with a large number of resins, fillers, etc.; inexpensive.
- **Application:** Motor housing, telephones, auto distributors, electrical fixtures.

17. What are metallic glasses?

Metallic glasses have the properties of metals and glasses such that they have ductility, malleability and brittleness. Ferromagnetic metallic glasses are in the form of ribbons and are used as light weight magnetic cores having no losses and high energy products.

18. What are advantages of FRP?

- High strength to weight ratio
- High heat resistance
- Low cost tooling
- High electrical conductivity

PART-B

1. Describe the molecular structure, properties and application of the following polymers.

- I. Polyvinyl chloride (PVC)
- II. Polystyrene (PS)
- III. Polyethylene terephthalate (PET)
- IV. Poly carbonate

Hints:

name	application example	$T_g/^\circ\text{C}$	$T_m/^\circ\text{C}$
thermoplastics			
low-density polyethylene, LDPE	foils, electr. insulations	-110...-20	100...110
high-density polyethylene, HDPE	tubes, bottles, household articles	-100...-20	125...135
polypropylene, PP	tubes, food packages, electr. insulation	-20...0	160...175
polystyrene, PS	toys, acoustic or thermal insulation, packages	100	<i>am</i> / 270
polyvinyl chloride, PVC	tubes, packages, floor coverings, window frames	70...90	<i>am</i> / 212
polymethylmethacrylate, PMMA	windows (e. g., in airplanes), lighting technology	100	<i>am</i>
polyamide, PA	gearwheels, ball bearing cages, bearings	40...150	170...300
polycarbonate, PC	casings, gearwheels, valves, tapes, packages	150	<i>am</i> / 220...260
polytetrafluor ethylene, PTFE	gaskets, bearings, food industry	126 ^a	327
polyethylene-terephthalate, PET	glues, connectors, roofings, tanks	80	<i>am</i> / 240...250

2. Explain engineering polymer in detail.

Hints:

- Linear, where 'mer' units are joined together end to end in single chains.
E.g.: PVC, nylon.
- Branched, where side-branch chains are connected to main ones. Branching of polymers lowers polymer density because of lower packing efficiency
- Cross-linked, where chains are joined one to another at various positions by covalent bonds. This cross-linking is usually achieved at elevated temperatures by additive atoms.
E.g.: vulcanization of rubber
- Network, trifunctional mer units with 3-D networks come under this category.
E.g.: epoxies, phenol-formaldehyde.

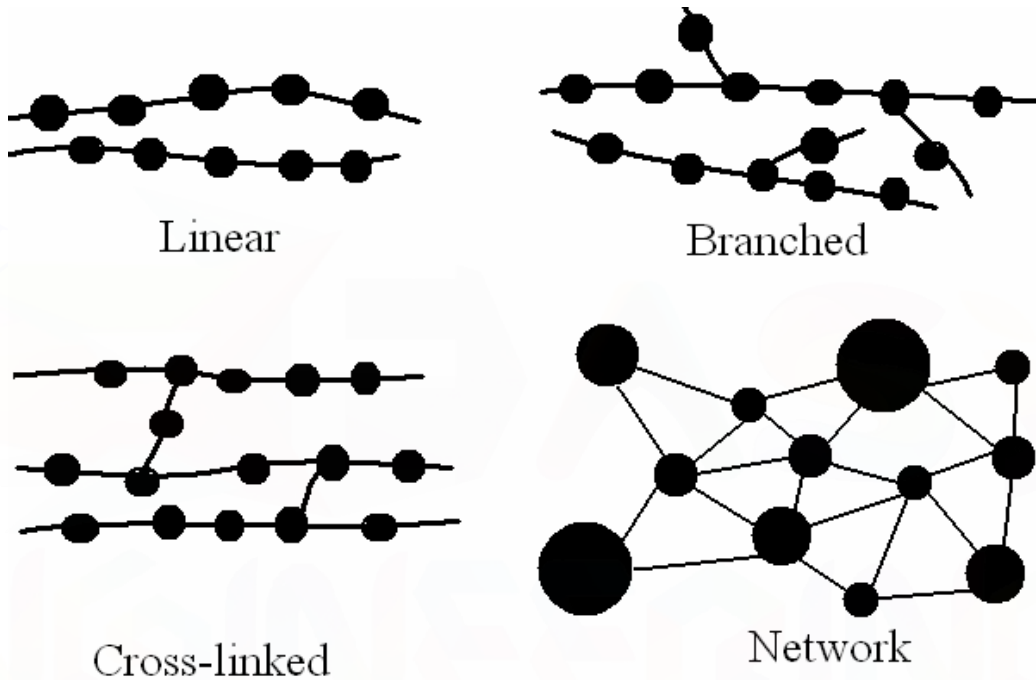

3. Describe the polymerization and additional polymerization.

Hints:

Polymerization

- The synthesis of the large molecular weight polymers is termed polymerization;
- Monomer units are joined over and over, to generate each of the constituent giant molecules.
- Two general classifications—addition and condensation according to the reaction mechanism, as discussed below.

Addition Polymerization

- Addition polymerization (sometimes called chain reaction polymerization)
- The composition of the resultant product molecule is an exact multiple for that of the original reactant monomer.
- Three distinct stages—initiation, propagation, and termination—are involved in addition polymerization.

4. Writeshort notes on FRP?

Hints:

Polymer–Matrix Composites

- Polymer-matrix composites (PMCs) consist of a polymer resin as the matrix, with fibers as the reinforcement medium.

Glass Fiber-Reinforced Polymer (GFRP) Composites

1. It is easily drawn into high-strength fibers from the molten state.
2. It is readily available and may be fabricated into a glass-reinforced plastic economically using a wide variety of composite-manufacturing techniques.
3. As a fiber, it is relatively strong, and when embedded in a plastic matrix, it produces a composite having a very high specific strength.
4. When coupled with the various plastics, it possesses a chemical inertness that renders the composite useful in a variety of corrosive environments.

Carbon Fiber-Reinforced Polymer (CFRP) Composites

1. Carbon fibers have the highest specific modulus and specific strength of all reinforcing fiber materials.
2. They retain their high-tensile modulus and high strength at elevated temperatures; high-temperature oxidation, however, may be a problem.
3. At room temperature carbon fibers are not affected by moisture or a wide variety of solvents, acids, and bases.
4. These fibers exhibit a diversity of physical and mechanical characteristics, allowing composites incorporating these fibers to have specific engineered properties.
5. Fiber and composite manufacturing processes have been developed that are relatively inexpensive and cost effective.

5. Differentiate thermosetting and thermoplastic polymers.

Hints:

Thermosetting	Thermoplastic
<ol style="list-style-type: none">a) Covalent bonds with cross-linking between chains.b) They are more strength and harder than thermoplastic.c) This process is not reversible hence, thermosets can not be recycled.d) E.g.: Acrylics, PVC, Nylons, Perspex glass, etc.	<ol style="list-style-type: none">a) They are linear chain without cross-linking and branching.b) they are usually supplied as granular materialsc) increasing ability to deform plastically with increasing temperature.d) E.g.: Acrylics, PVC, Nylons, Perspex glass, etc.

6. Classify composite materials and list two properties and application of them.

Hints:

A composite is a material that consists of at least two distinct materials. Thus, numbers of composites are possible. For ease of recognition, they are classified based on two criteria.

Based on type of matrix material as metal-matrix composites, polymer-matrix composites and ceramic-matrix composites.

Based on size and shape dispersed phase as particulate reinforced composites, fiber-reinforced composites and structural composites.

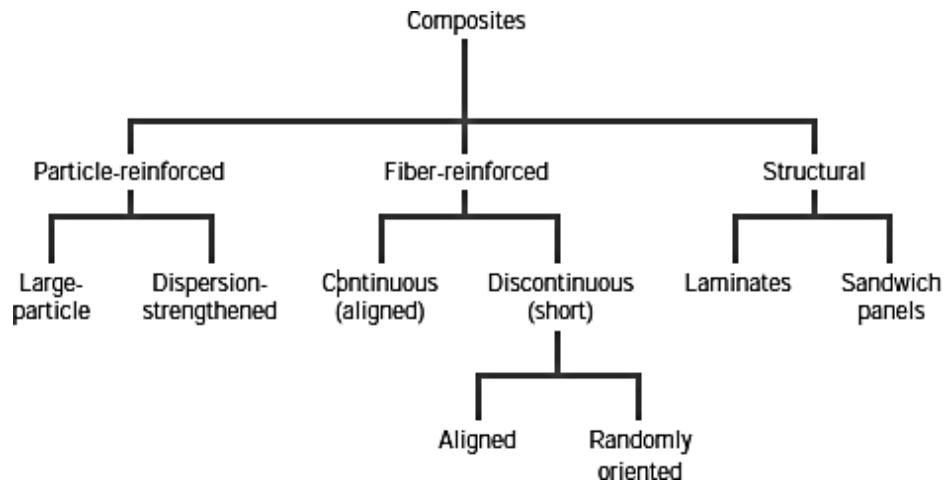

UNIT-V -MECHANICAL PROPERTIES AND DEFORMATION MECHANISMS

PART-A

1. Define slip.

Plastic deformation as the result of dislocation motion; also, the shear displacement of two adjacent planes of atoms.

2. Define twinning.

A twin boundary is a special type of grain boundary across which there is a specific mirror lattice symmetry; that is, atoms on one side of the boundary are located in mirror image positions of the atoms on the other side

3. What is a fracture?

Simple fracture is the separation of a body into two or more pieces in response to an imposed stress that is static (i.e., constant or slowly changing with time) and at temperatures that are low relative to the melting temperature of the material.

4. Write types of fractures.

- Ductile Fracture
- Brittle Fracture
- Fatigue fracture and
- Creep fracture.

5. What is fatigue fracture?

Materials subjected to extended cyclic loading may result in delayed fracture called fatigue fracture.

6. What is creep?

Under the influence of a constant applied stress many materials continue to deform indefinitely. This process is called creep.

7. What is brittle fracture?

The failure of a material without any plastic deformation is called brittle fracture.

8. What are transgranular and intergranular fracture?

In many brittle crystalline materials, crack propagation occurs along specific crystallographic planes; such a process is termed cleavage. This type of fracture is said to be transgranular in transgranular fracture because fracture cracks pass through grains. The fractured surface looks grainy or granular. In some alloys, crack propagation along grain boundaries is also possible; this is termed Intergranular fracture. This yields a relatively shiny and smooth fracture surface.

9. What are creep and creep resistance

Creep is the property of a material by which it deforms continuously under a steady load (yielding). The deformation during creep is non-recoverable. The creep can produce fracture or rupture even though the applied stress is lower than the Ultimate stress. So the creep in materials should be avoided, particularly at high temperatures.

Creep resistance is the property of the material by which the continuation of creep is stopped.

10. What are the two types of Deformation in metals?

- Elastic deformation
- plastic deformation

11. What is plastic deformation?

Deformation that is permanent or non recoverable after release of the applied load. It is accompanied by permanent atomic displacements.

12. What is Elastic deformation?

Deformation that is nonpermanent, that is, totally recovered upon release of an applied stress.

PART-B

1. What are slip and twinning? What are their characteristics?

Hints:

- Plastic deformation as the result of dislocation motion; also, the shear displacement of two adjacent planes of atoms.

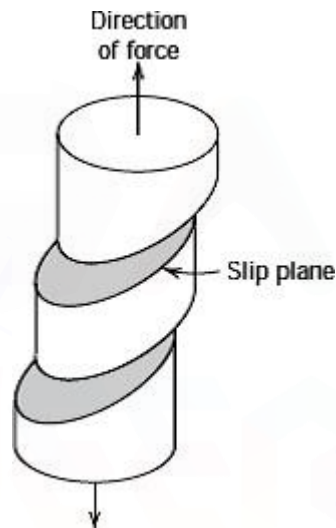

- A twin boundary is a special type of grain boundary across which there is a specific mirror lattice symmetry;

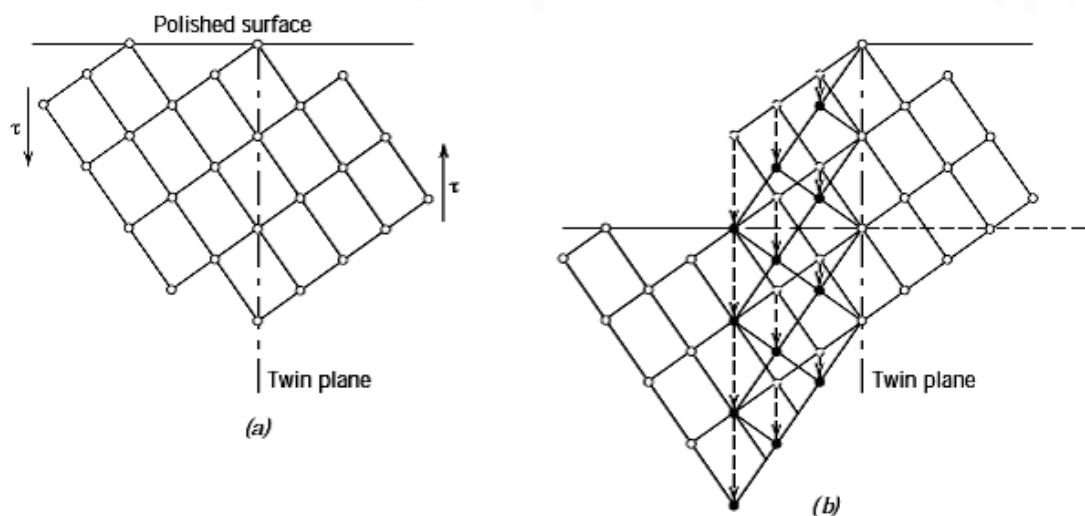

2. Discuss characteristics of ductile fracture and brittle fracture.

Hints:

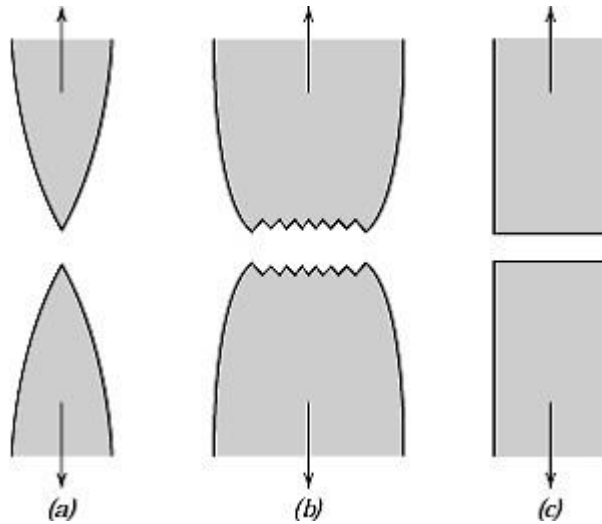

- Ductile fracture surfaces will have their own distinctive features on both macroscopic and microscopic levels.
- These highly ductile materials neck down to a point fracture, showing virtually 100% reduction in area.
- Brittle fracture takes place without any appreciable deformation, and by rapid crack propagation.
- The direction of crack motion is very nearly perpendicular to the direction of the applied tensile stress and yields a relatively flat fracture surface, as indicated

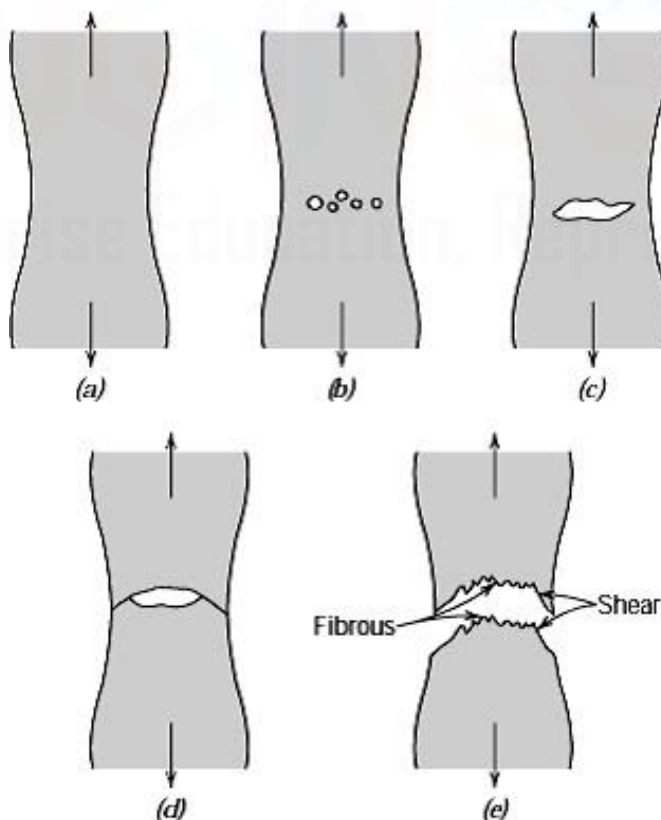

3. Explain the testing procedure for determining the following properties.

I. Brinell hardness testing

Hints:

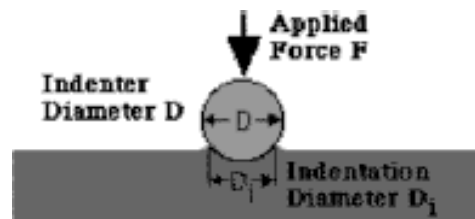

$$\text{BHN} = \frac{F}{\frac{\pi}{2} D \cdot (D - \sqrt{D^2 - D_1^2})}$$

- In Brinell tests, as in Rockwell measurements, a hard, spherical indenter is forced into the surface of the metal to be tested.
- The diameter of the hardened steel (ortungsten carbide) indenter is 10.00 mm (0.394 in.). Standard loads range between 500 and 3000 kg in 500-kg increments
- Maximum specimen thickness as well as indentation position (relative to specimen edges) and minimum indentation spacing requirements are the same as for Rockwell tests.

4. Explain the testing procedure of Vickers hardness test

Hints:

The facility to convert the hardness measured on one scale to that of another is most desirable. However, since hardness is not a well-defined material property, and because of the experimental dissimilarities among the various techniques, a comprehensive conversion scheme has not been devised. Hardness conversion data have been determined experimentally and found to be dependent on material type and characteristics.

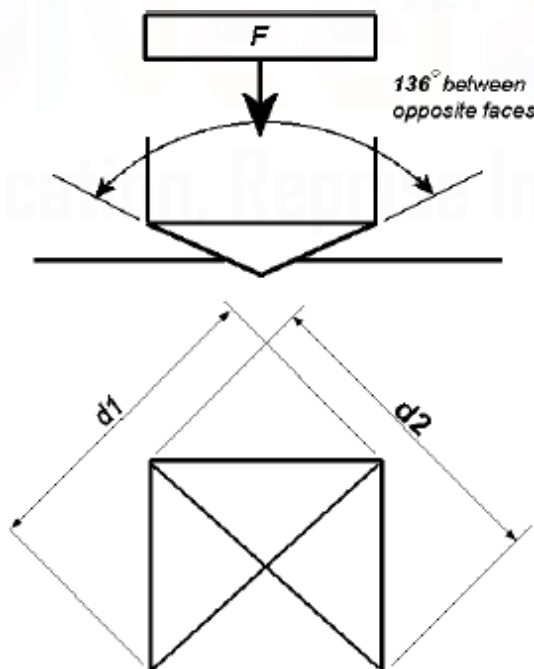

5. Explain the testing procedure of Rockwell hardness test

Hints:

The Rockwell tests constitute the most common method used to measure hardness because they are so simple to perform and require no special skills.

With this system, a hardness number is determined by the difference in depth of penetration resulting from the application of an initial minor load followed by a larger major load; utilization of a minor load enhances test accuracy.

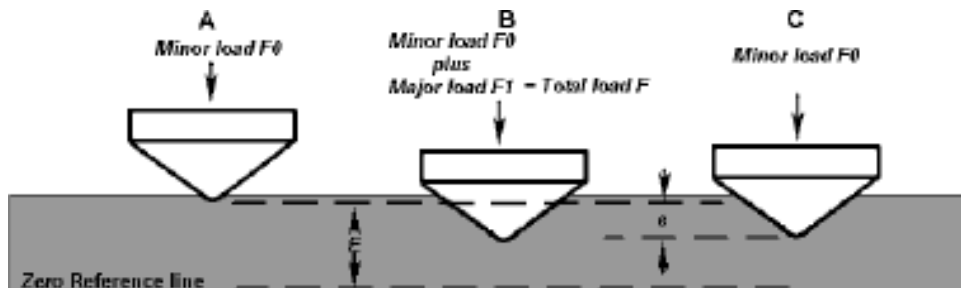

6. Compare Charpy and Izod impact test.

Hints:

A material's susceptibility to different kinds of fracture is measured using notched specimen subjected to impact load. Further study involves examining the fracture surfaces, and calculation of ductility.

Two kind of specimen configurations & loading directions:

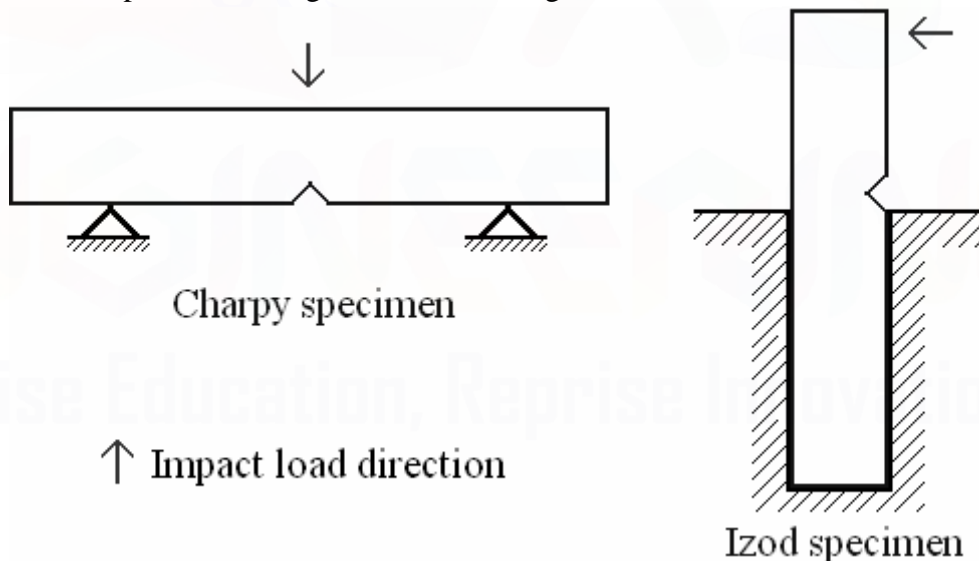

7. Draw a typical creep curve and brief on the mechanism

Hints:

- Deformation that occurs under constant load/stress and elevated temperatures which is time-dependent is known as creep.
- Creep deformation (constant stress) is possible at all temperatures above absolute zero. However, it is extremely sensitive to temperature.
- Hence, creep is usually considered important at elevated temperatures (temperatures greater than $0.4 T_m$, T_m is absolute melting temperature).
- Creep test data is presented as a plot between time and strain known as creep curve.
- The slope of the creep curve is designated as creep rate.

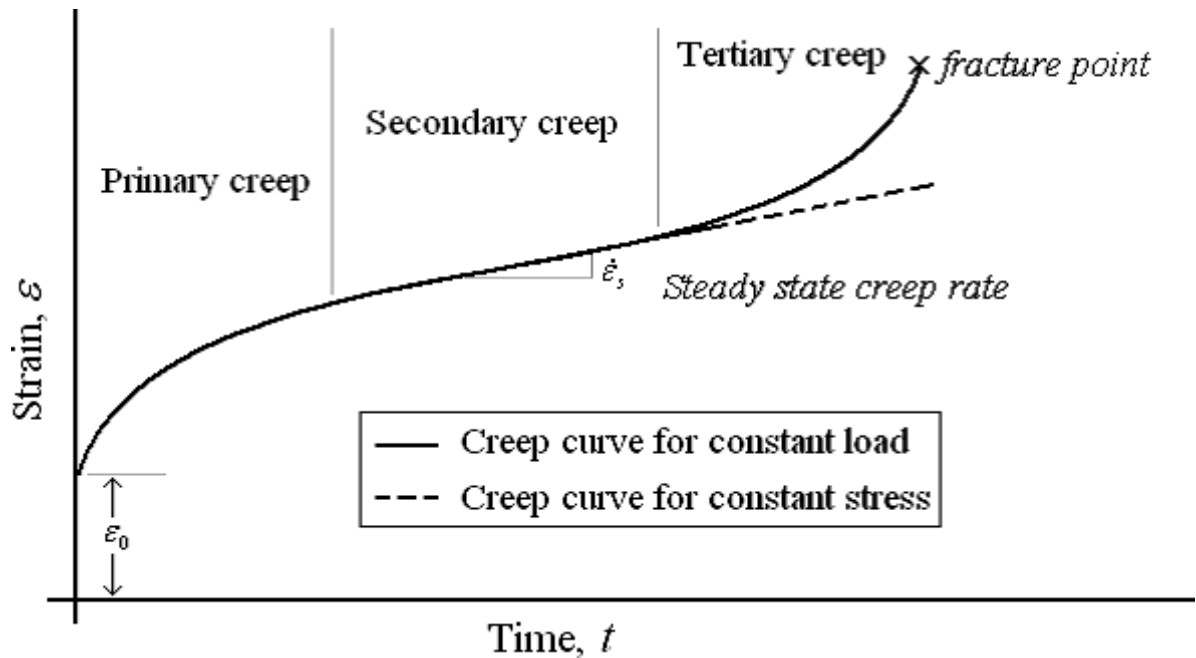

8. Draw S-N curve for ferrous and non-ferrous metals and explain how endurance strength can be determined.

Hints:

Fatigue test, usually, involves applying fluctuating load cyclically.

- A specimen of rotating beam type is often used because of its simplicity.
- Fatigue data is usually presented by plotting maximum stress (S) against number of cycles to fracture (N), using a logarithmic scale for the latter variable.

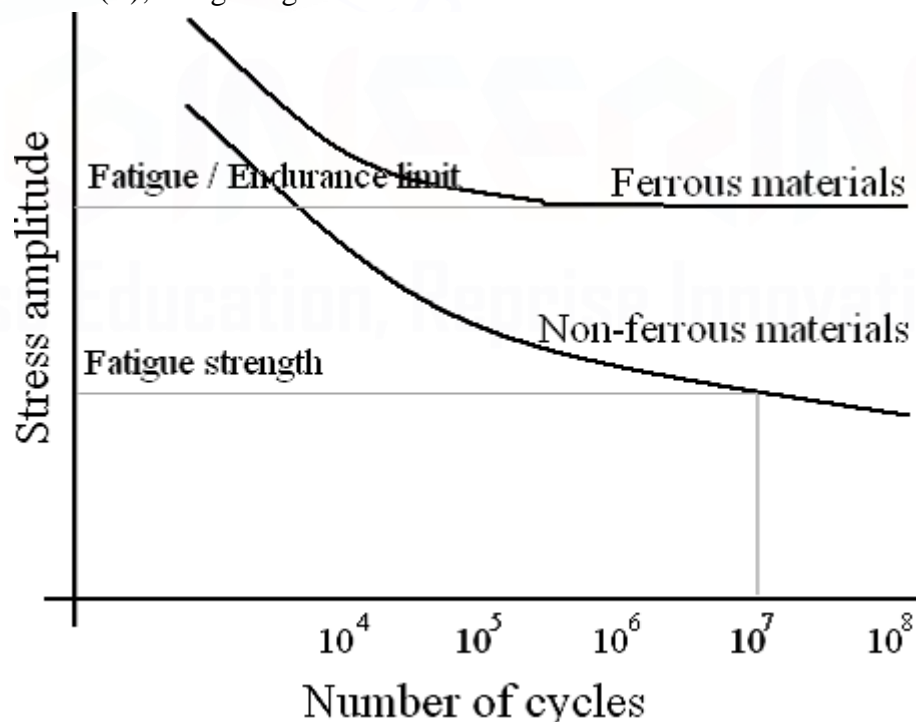

Endurance ratio – ratio of fatigue stress to tensile stress of a material. For most materials it is in the range of 0.4-0.5.